

Diodes type D71 are of modern design with internal spring loaded contacts, high alumina ceramic insulator and pressure welded encapsulation. Designed for use in power electronic circuits and equipment under normal operating conditions.

KEY PARAMETERS

U_{RRM}	up to 2200 V
$I_{F(AV)}$	500 A
I_{FSM}	10000 A

FEATURES

- all diffused design
- high current capabilities
- high surge current capabilities
- high rates voltages
- low thermal impedance
- tested according to IEC standards
- compact size and small weight

APPLICATION

- High Voltage Power Supplies
- Motor Control
- Battery Chargers
- Free Wheeling Diode
- Resistance Welding

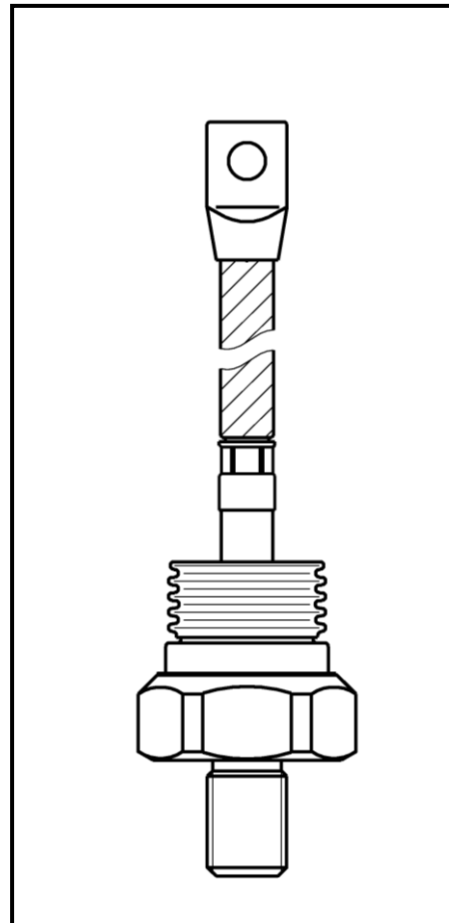

See package details for further information

Designed for use in high power industrial and commercial power electronic circuits and equipment where high currents are encountered and high reliability is essential.

ORDERING INFORMATION

When ordering please refer to device code builder presented below.
Please use the complete part number when ordering, quote or in any future correspondence relating to your order.

D71-500-□□-□0

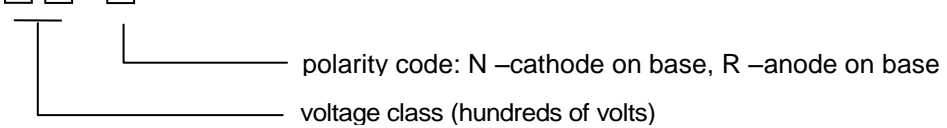

ELECTRICAL PARAMETERS

Voltage ratings

Voltage class	U_{RRM}	U_{RSM}	I_{RRM}
	V	V	mA
04	400	500	50
06	600	700	
08	800	900	
10	1000	1100	
12	1200	1300	
14	1400	1600	
16	1600	1800	
18	1800	2000	
20	2000	2200	
22	2200	2400	

Electrical properties

Parameter	Unit	Test conditions	Value
Average forward current @ case temperature	$I_{F(AV)}$	A	500
	T_c	°C	$U_{RRM} \leq 1200V$ 125 $U_{RRM} > 1200V$ 110
RMS forward current	$I_{F(RMS)}$	A	785
Surge current	I_{FSM}	A	$T_j = T_{jmax}$, $U_R = 0,8U_{RRM}$, $t_p = 10ms$
I^2t – value	I^2t	kA^2s	$T_j = T_{jmax}$, $U_R = 0,8U_{RRM}$, $t_p = 10ms$
Forward voltage drop max.	U_{FM}	V	$T_j = 25^\circ C$, $I_{FM} = 1500A$
Threshold voltage	$U_{F(T0)}$	V	0,62
Slope resistance	r_F	mΩ	0,45

Thermal properties

Parameter	Unit	Test conditions	Value
Thermal resistance, junction to case	R_{thJC}	°C/W	DC 0,10
Thermal resistance, case to heatsink	R_{thCS}	°C/W	0,04
Operating junction temperature	$T_{jmin} \dots T_{jmax}$	°C	$U_{RRM} \leq 1200V$ -40...+190 $U_{RRM} > 1200V$ -40...+175
Storage temperature	T_{stg}	°C	-40...+175

Mechanical properties

Parameter	Unit	Value
Mounting torque	M	Nm 38...41
Weight	m	g 520

Package details

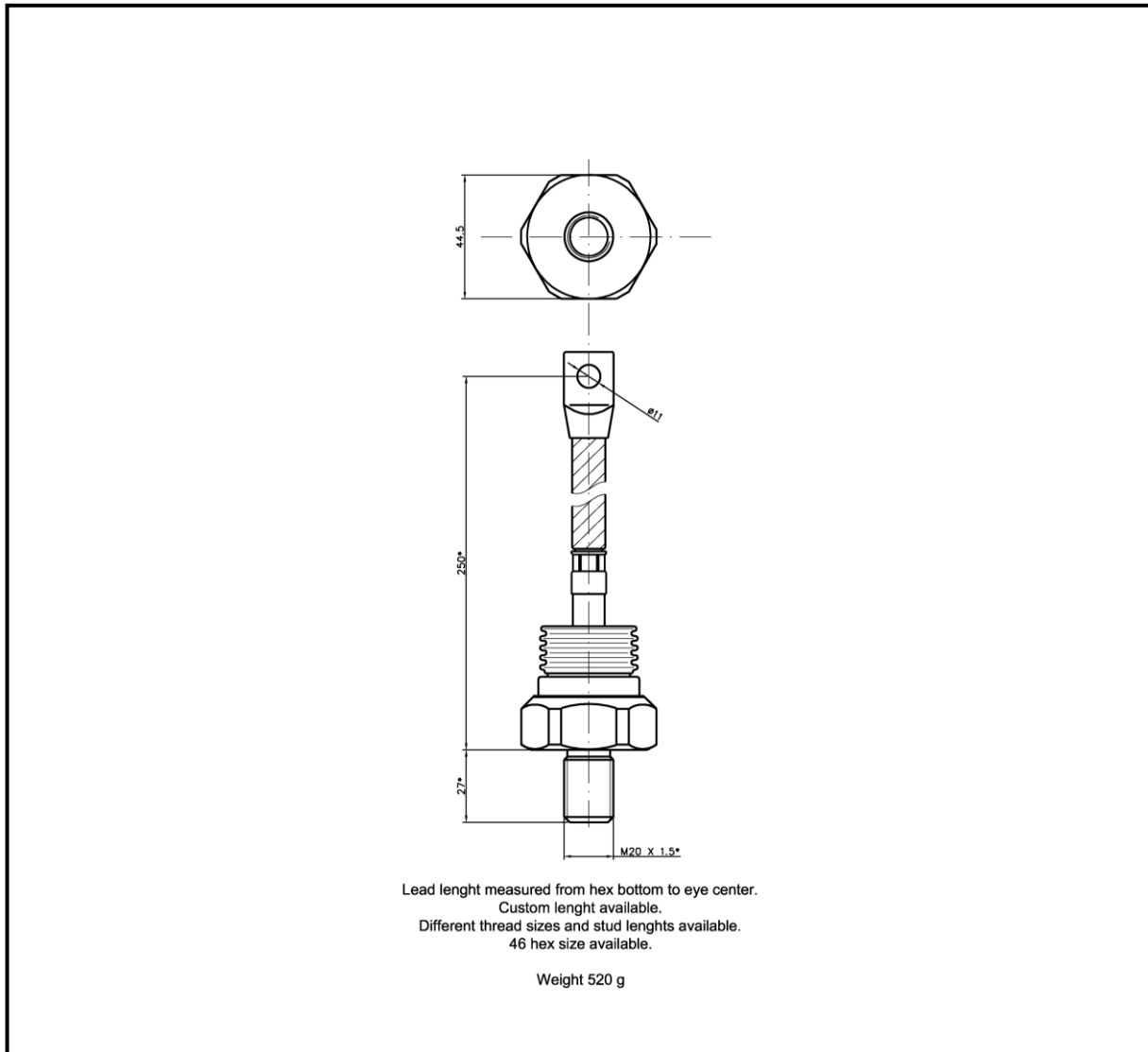

For further package information, please contact Sales & Marketing Department. All dimensions in mm, unless stated otherwise.
Do not scale

CHARACTERISTICS

KUBARA LAMINA SA
Puławska 34
PL-05-500 Piaseczno
POLAND

Tel.: +48-22-398 94 09
Tel.: +48-22-757 76 60
Fax: +48-22-750 08 84
e-mail: sekretariat@kubara-lamina.com
www.kubara-lamina.com

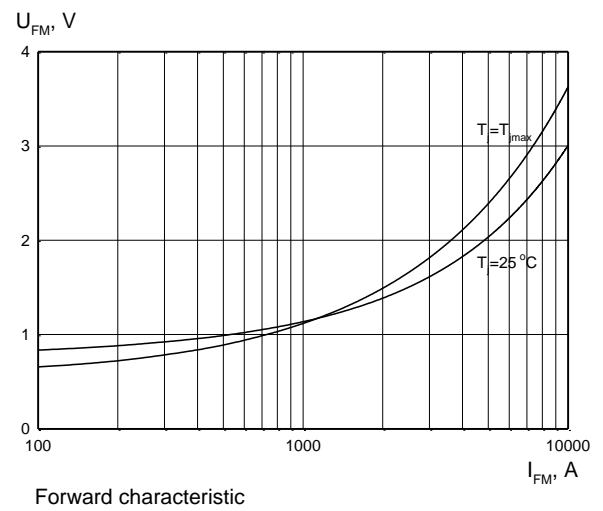
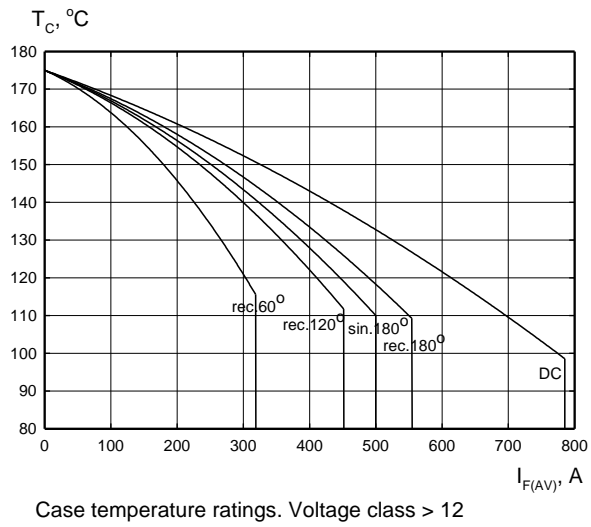
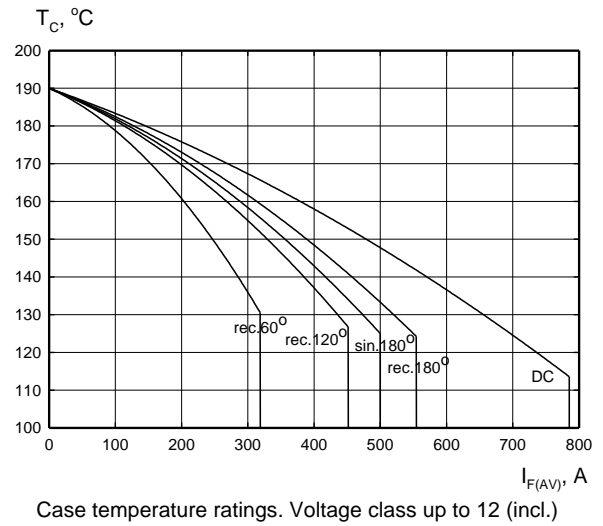
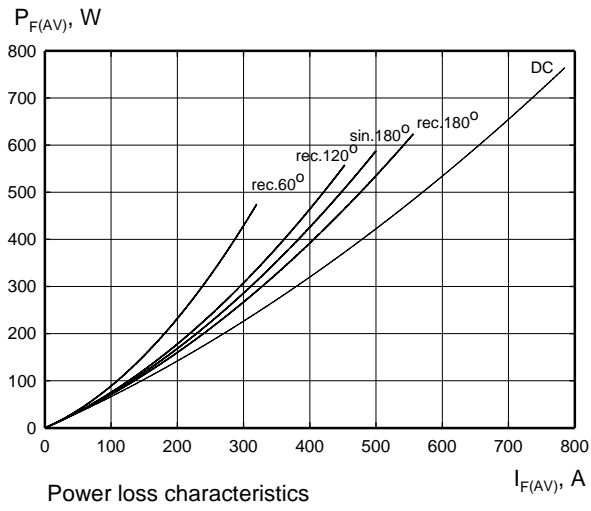

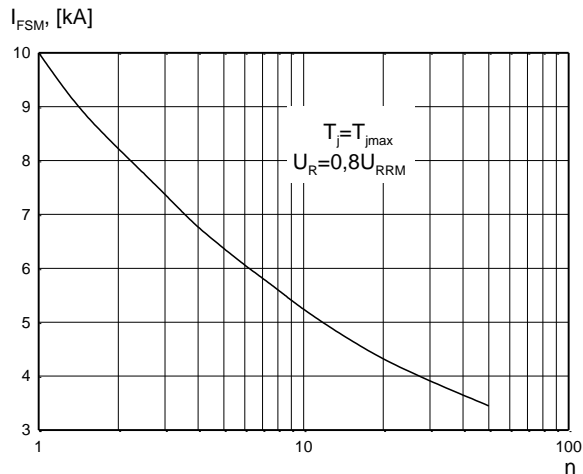

Non-repetitive surge current rating

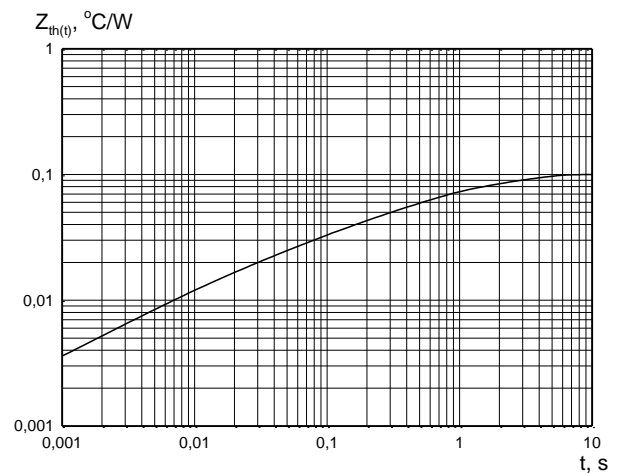

Transient thermal impedance

HEATSINKS

KUBARA LAMINA SA has its own proprietary range of extruded aluminium heatsinks designed to optimise the performance of our semiconductors with natural and forced air flow.

POWER ASSEMBLY CAPABILITY

KUBARA LAMINA SA provides a support for those customers requiring more than a basic semiconductor and offers precisely assembled Power Blocks according to factory or customer standards.